

## DESCRIPTION

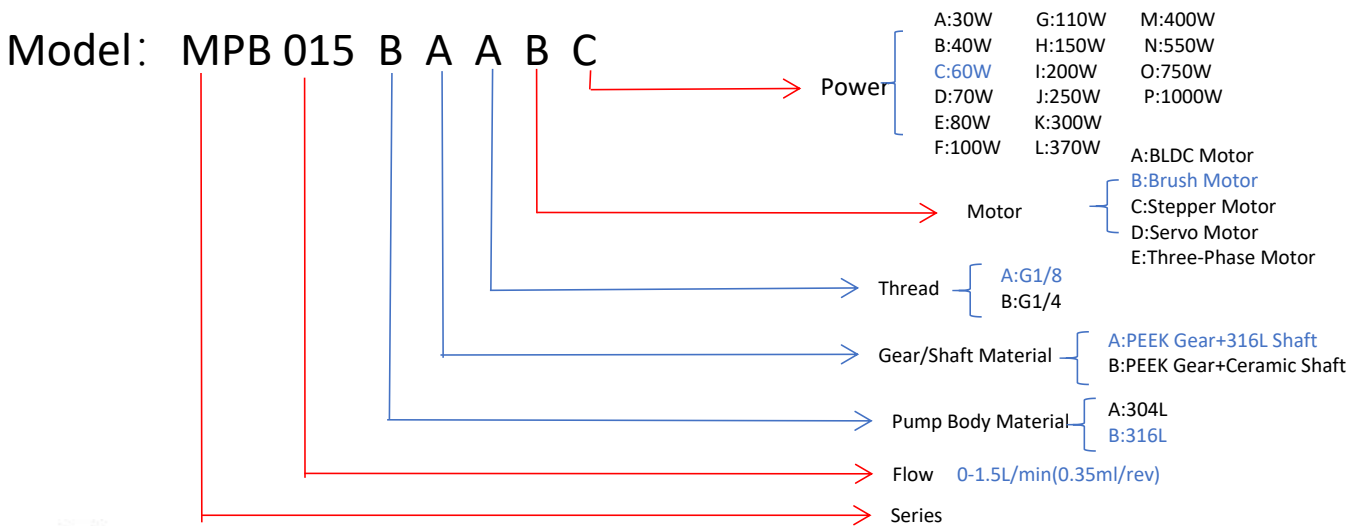

## Advantages

1. Precise transmission without pulsation, through the gear to provide continuous accurate fluid delivery.
2. Strong vacuum suction capacity, high and stable conveying pressure, can achieve high pressure conveying of low viscosity liquid.
3. No leakage, magnetic drive and static O-ring seal can ensure that the medium in the pump is isolated from the outside world, to achieve no leakage.

Parameter	Parameter detail
Viscosity Range:	0~3000cps
Tempature Range:	-40°C~120°C
Pressure:	15Bar
Types of Media:	Except for strong acids and bases
Inlet Filter:	Recommended 400 mesh
Inlet vacuum level:	-0.85Bar
Motor:	60W Brushed Motor
Noise:	4500rpm < 60dB
Speed:	0~4500rpm

## Exploded View

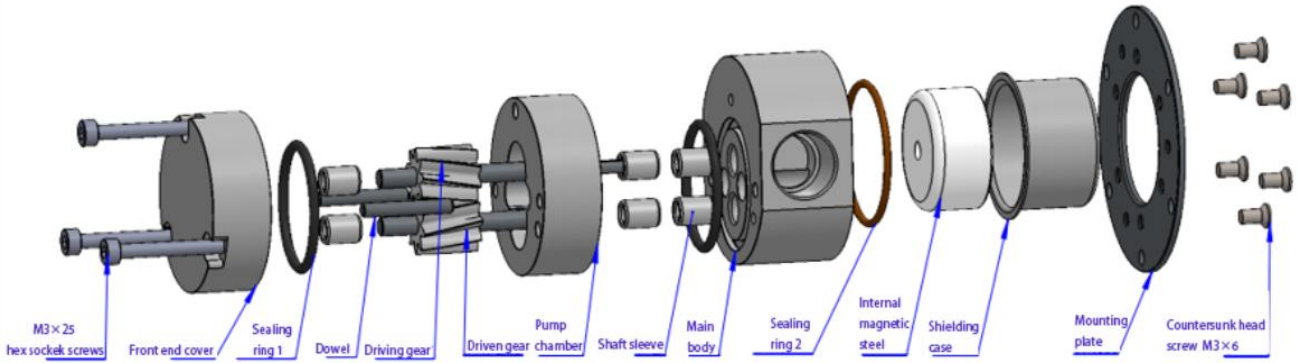

## Dimension

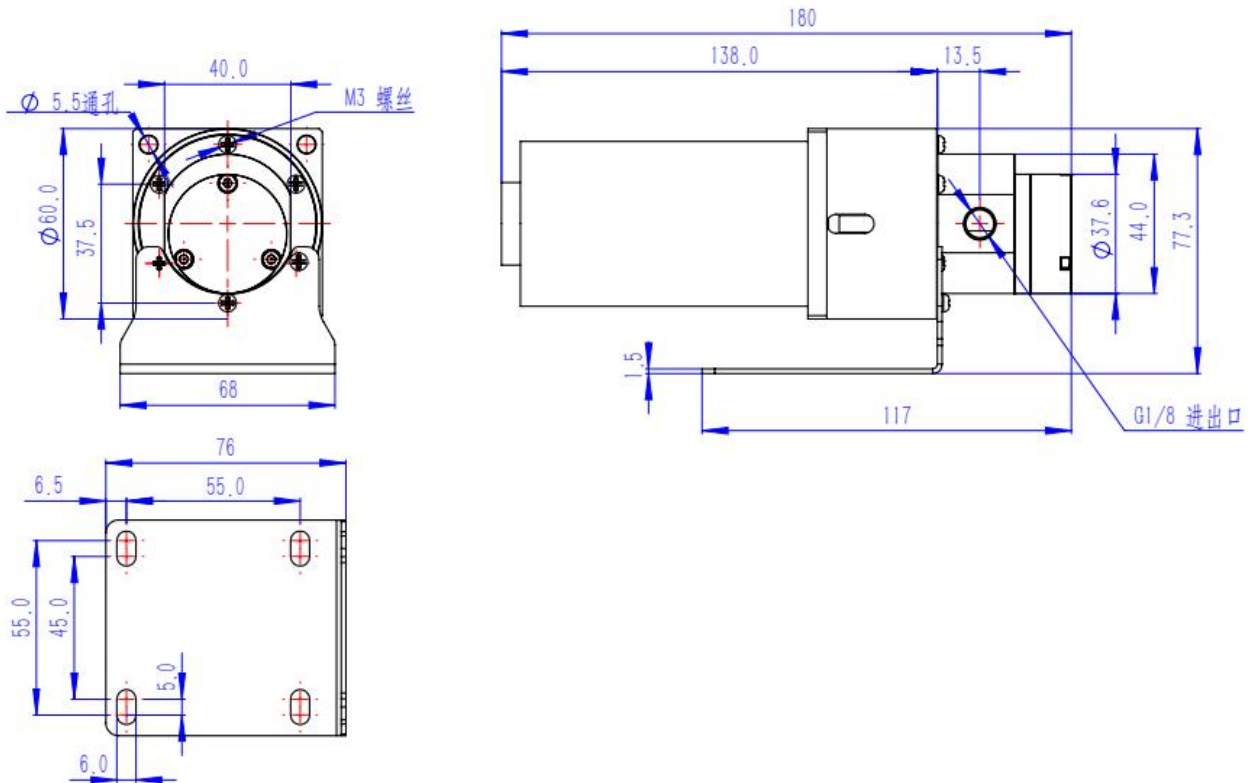

## ⊙ Equipped With BLDC Motor

- ◆ Brushed DC motor, easy to control, high speed for high efficiency liquid delivery, cost effective

### Motor Parameters

Power:60W Current:3.5A Voltage:24V Speed:4500rpm

## 📄 Wiring Instructions

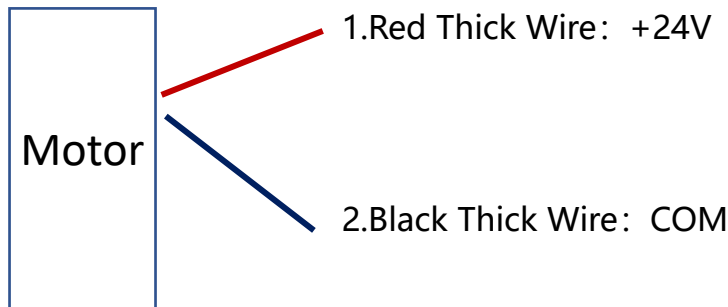

## 📄 Flow Curve

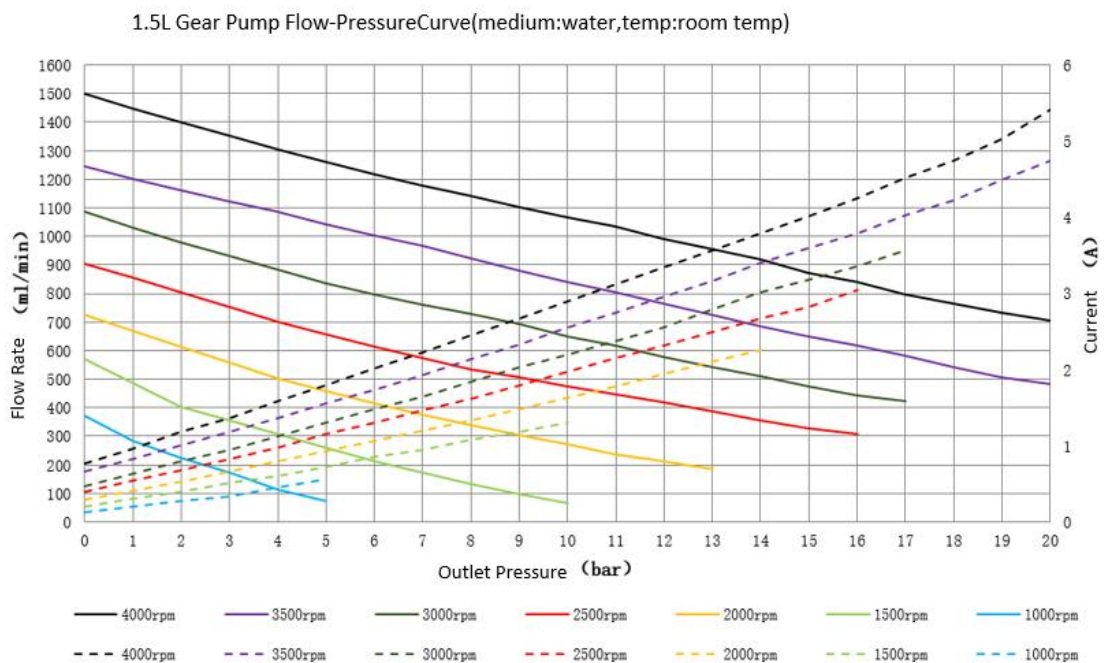

## Installation and use instructions

1. Take out the inlet and outlet plug and install the matching thread joint. Pump inlet and outlet joints must be wrapped with raw material belt, especially at the inlet, such as leakage will have no suction.
- 2, pump as close to the liquid source as possible, the inlet and outlet pipe size can not be less than the pump body joint size, as far as possible to shorten the length of the pipe, if the pipe is very long, please increase the diameter of the pipe.
3. Install in accordance with the direction indicated by the arrow on the end cover, otherwise the liquid will not be absorbed.

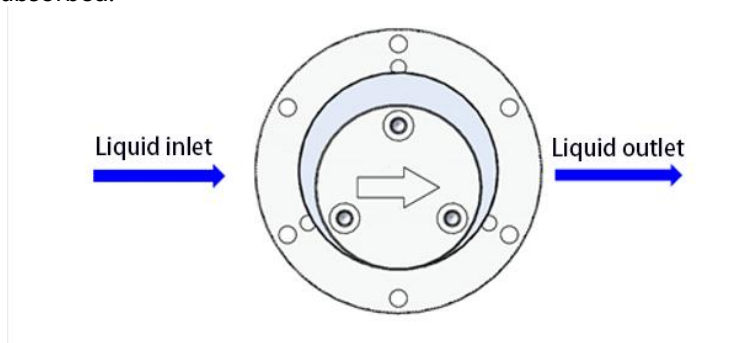

- 4, please ensure that there is liquid in the pump body, if the removal of the tube is not used for a long time, please install the plug to protect the gear. Otherwise dry transfer will result in permanent damage to the pump.
5. When the pump is used for the first time, please flush the pump pipe, install the filter on the inlet pipe, and the filtration accuracy requires that the particle diameter in the liquid is less than 20 microns.
6. When the pump is working continuously, please cool the pump in time.

## Applications

With the rapid development of domestic micro magnetic pump technology, micro magnetic pump has been widely used in various fields of society, such as food and beverage, cosmetics, mechanical coding, life science, chemical measurement, etc., and has gradually become an indispensable core component of industrial equipment.

